

LOC	DIST	REVISIONS			
P	LTR	DESCRIPTION	DATE	DWN	APVD
AA	22	A1	REVISED PER ECO-11-005033	29MAR11	RK HMR

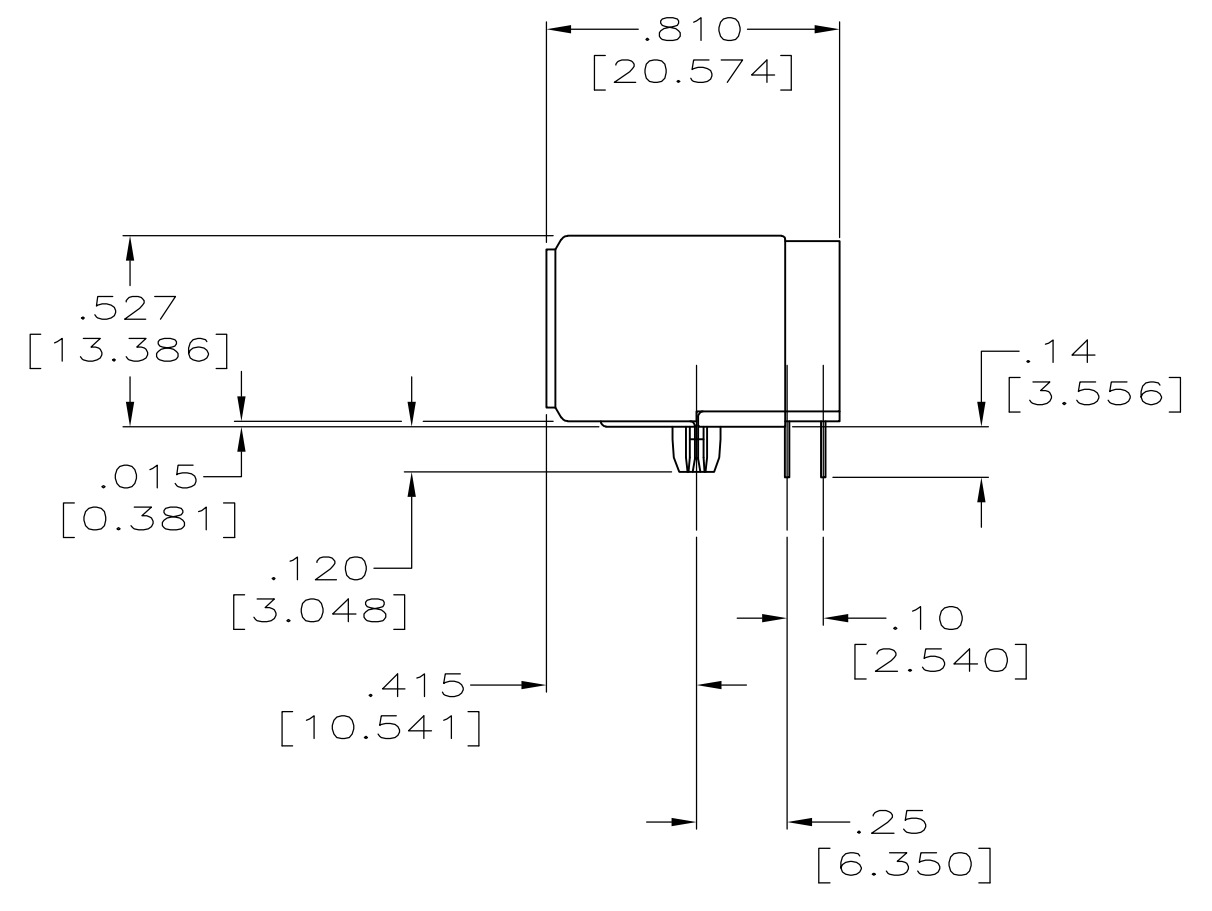

- 1. MATERIAL: HOUSING - HTN NYLON, BLACK, IR REFLOW PROCESSING COMPATIBLE, UL 94V-0. TERMINALS - .013[0.33] THICK PHOS BRONZE PLATED WITH .000050[1.27µm] THICK HARD GOLD IN LOCALIZED AREA AND .000150[3.81µm] THICK MATTE TIN IN SOLDER AREA OVER .000050[1.27µm] THICK NICKEL UNDERPLATE.
- 2. JACK CAVITY CONFORMS TO FCC RULES AND REGULATIONS, PART 68 SUBPART F.
- 3. ALL DIMENSIONS SHOWN ARE NOMINAL UNLESS OTHERWISE SPECIFIED.
- 4. ALL DIMENSIONS SHOWN IN BRACKETS [] ARE IN MILLIMETERS.

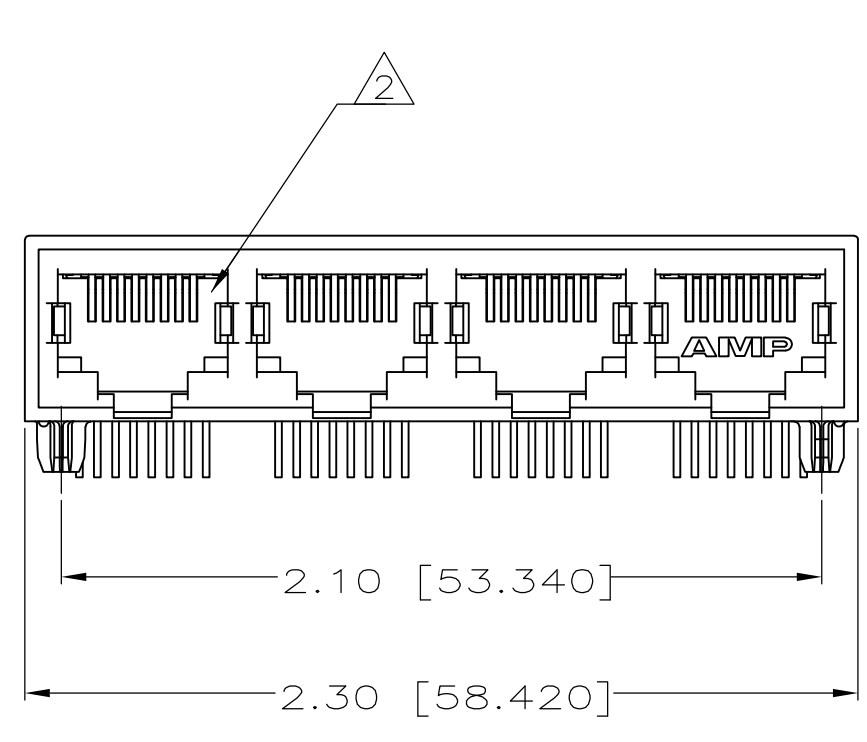
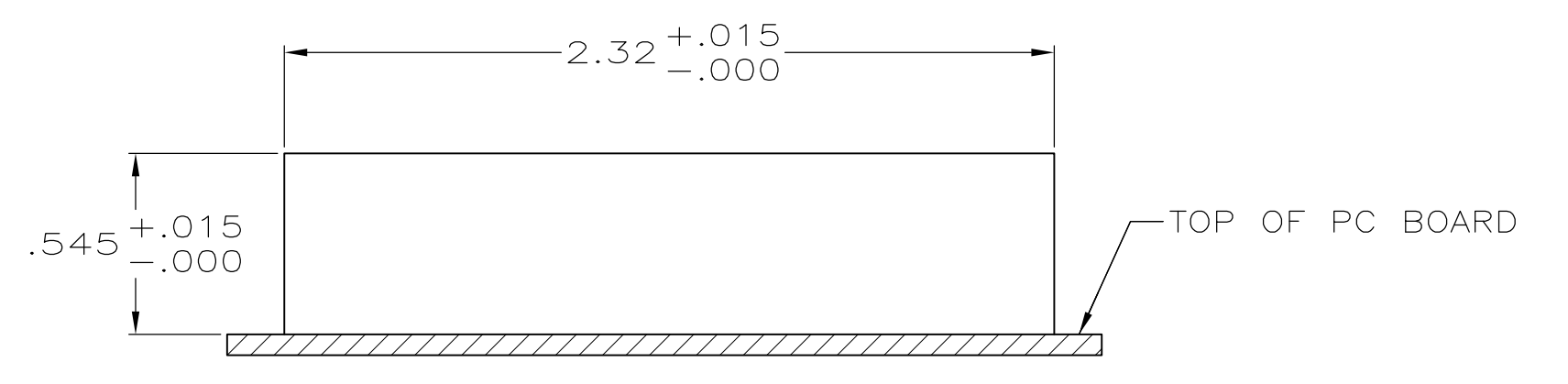
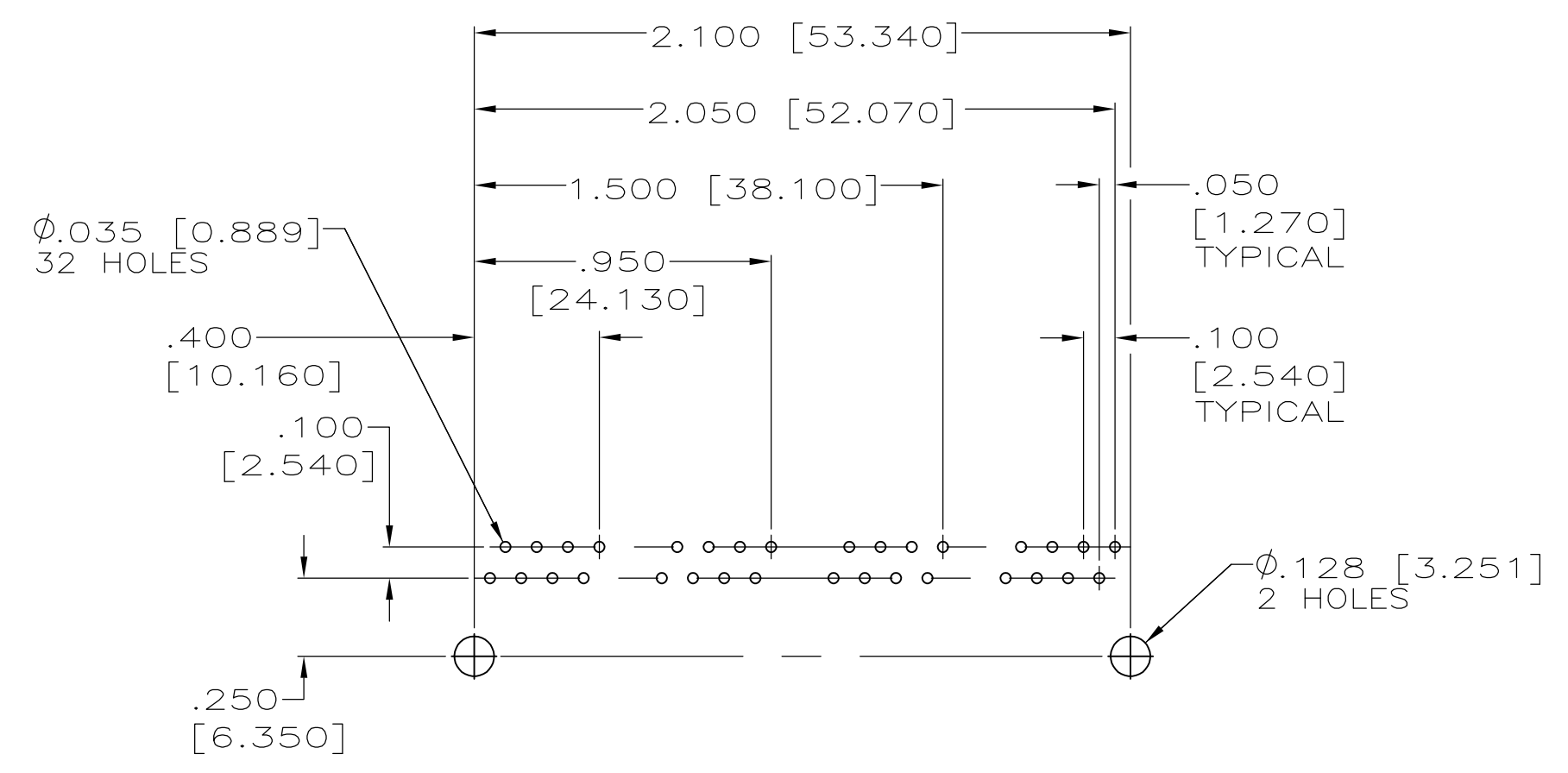

SUGGESTED PANEL CUTOUT

SUGGESTED PC BOARD LAYOUT
 COMPONENT SIDE
 SEE APPLICATION SPECIFICATION

5557562-1
 PART NO.

THIS DRAWING IS A CONTROLLED DOCUMENT.		DWN G. ATTADIA - DOCK5 10JUN2005	TE Connectivity	
DIMENSIONS: mm[INCHES]		CHK J. WESTMAN 10JUN2005	NAME S. FLICKINGER	
TOLERANCES UNLESS OTHERWISE SPECIFIED:		APVD S. FLICKINGER 10JUN2005	PRODUCT SPEC 108-1392	
0 PLC ± -	1 PLC ± -	APPLICATION SPEC 114-2048	SIZE A2	CAGE CODE 00779
2 PLC ± .01[0.254]	3 PLC ± .005[0.127]	WEIGHT -	DRAWING NO G-5557562	RESTRICTED TO -
4 PLC ± - ± -	ANGLES ± - ± -	CUSTOMER DRAWING	SCALE 2:1	SHEET 1 of 1
MATERIAL 1	FINISH 1	REV A1		